

M25N-2 (φ 25.6 x 30.8mm)

Carbon Brush



Weight:53.4g

Applications

Printer

External Dimensions

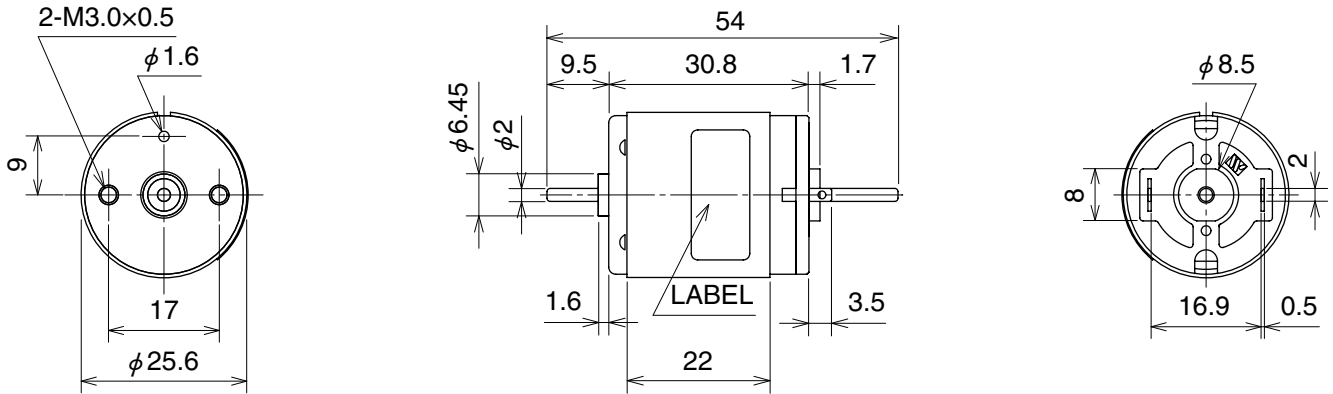

Unit: mm

Reference Characteristics

Model	Voltage		No Load		Rated Load		Rated Load		Starting Torque		Starting Current	Shaft length
	Operating	Rated	Speed	Current	Rated Load		Speed	Current	(gf·cm)	(mN·m)		
	(V)	(V)	(min ⁻¹)	(mA)	(gf·cm)	(mN·m)	(min ⁻¹)	(mA)				
M25N-2	12 to 34	31	11000	65	239	23.4	7163	983	685	67.1	2696	—*

※ Characteristics and the shaft length can be customized.

Characteristics

